

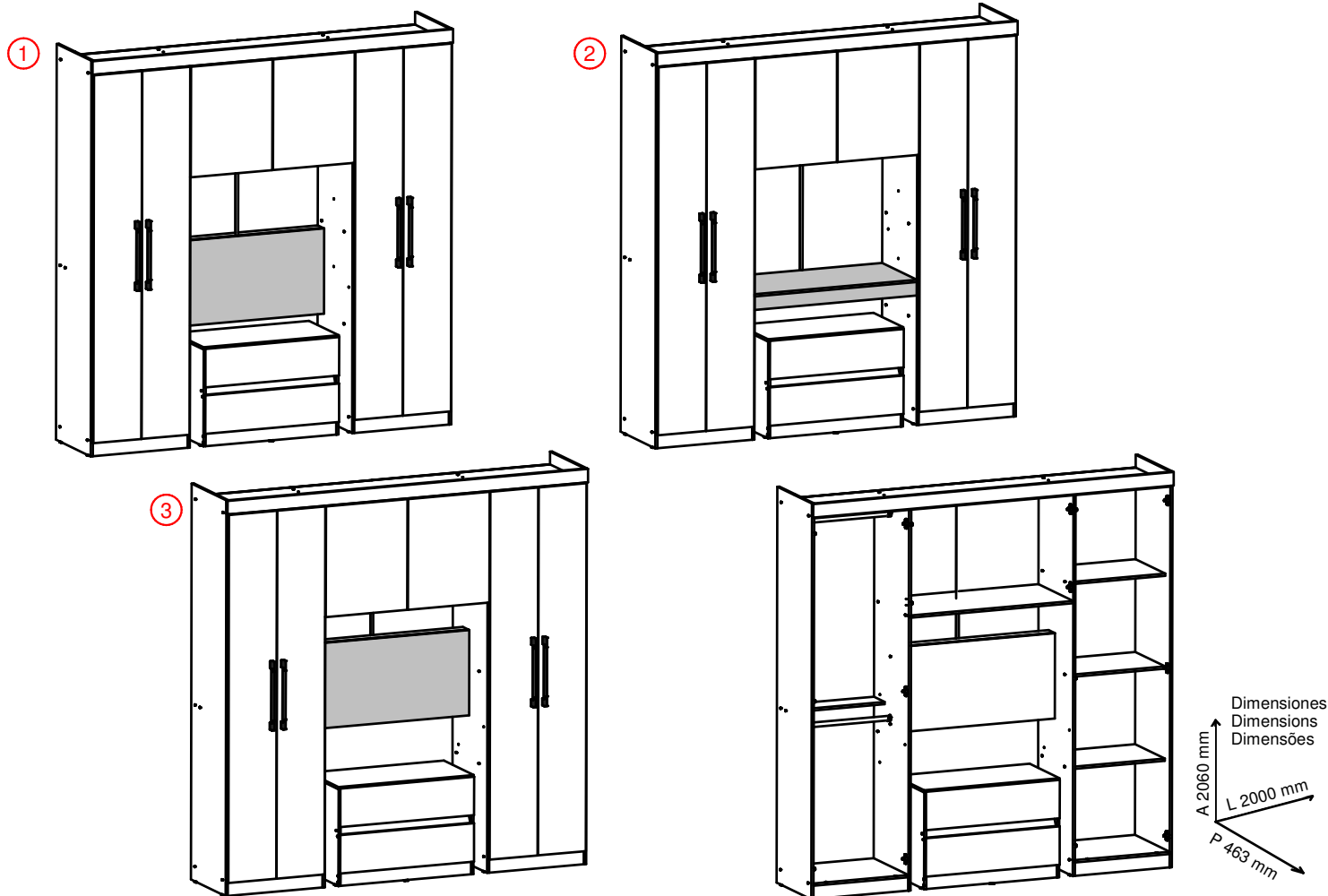

CARRARO
MÓVEIS

Ref. 837

Ropero 6 Puertas + Cómoda / 6-Door Wardrobe + Chest of Drawers / Roupeiro 6 Portas + Cômoda



(A) Parafuso 4 x 12 134 un.	(B) Parafuso 4 x 16 4 un.	(C) Parafuso 4 x 25 8 un.	(D) Parafuso 4 x 50 58 un.	(E) Paraf. 5/32" x 29/32" 4 un.	(F) 6 x 30 28 un.
(G) 30 un.	(H) 132 un.	(I) 4 un.	(J) 20 un.	(K) 29 un.	(L) 4 un.
(M) 4 un.	(N) 14 un.	(O) 16 un.		(P) 16 un.	(Q) Pegamento Glue Cola 1 un.
(R) 20 un.	(S) 50 un.	 4 un.			

Herramientas
Tools
Ferramentas



90 min.



Personas Necessarias
People Required
Pessoas Necessárias

②



Consejos de Conservación

- No debe utilizarse en la limpieza, abrasivos como lana de acero, alcohol, vinagre, limón, o productos corrosivos que puedan rayar o quitar la película protectora en los muebles.
- Cuando la limpieza de muebles en general, napa y formica, deben utilizarse un paño ligeramente humedecido y jabón suave.
- Para mover el móvil, es importante que este se eleve desde el suelo, debido a que el arrastre puede causar daño estructural.
- No deje a su móvil en exposición a la intemperie.

Conservation Tips

- Do not use abrasive products to clean such as steel wool, alcohol, vinegar, lemon, scouring powder, or corrosive products which can scratch or peel off the protective film of the furniture.
- The best way to clean your furniture is to use a slightly moistened cloth with a mild soap.
- To move the furniture assembled, it is important that it is lifted off the ground, because the drag it can cause structural damage.
- Do not leave your furniture in weather exposure.

Dicas de Conservação

- Não utilizar na limpeza produtos abrasivos tais como: palha de aço, álcool, vinagre, limão, saponáceo, ou produtos corrosivos que possam riscar ou descolar a película protetora dos móveis.
- Na limpeza de móveis em geral, napa e fórmicas, deve ser utilizado um pano levemente umedecido e sabão neutro.
- Para a movimentação do móvel, é importante que este seja levantado do chão, pois ao arrastá-lo pode causar avarias estruturais.
- Não deixe o móvel em exposição a intempéries.

Certificado de Garantia

A garantía dos produtos fabricados pela Carraro, abrange eventuais defeitos/vícios de fabricação, no prazo estabelecido pelo Código de Defesa do Consumidor, em seu artigo 26,II, o qual prevê a garantia legal de 90 (noventa) dias.

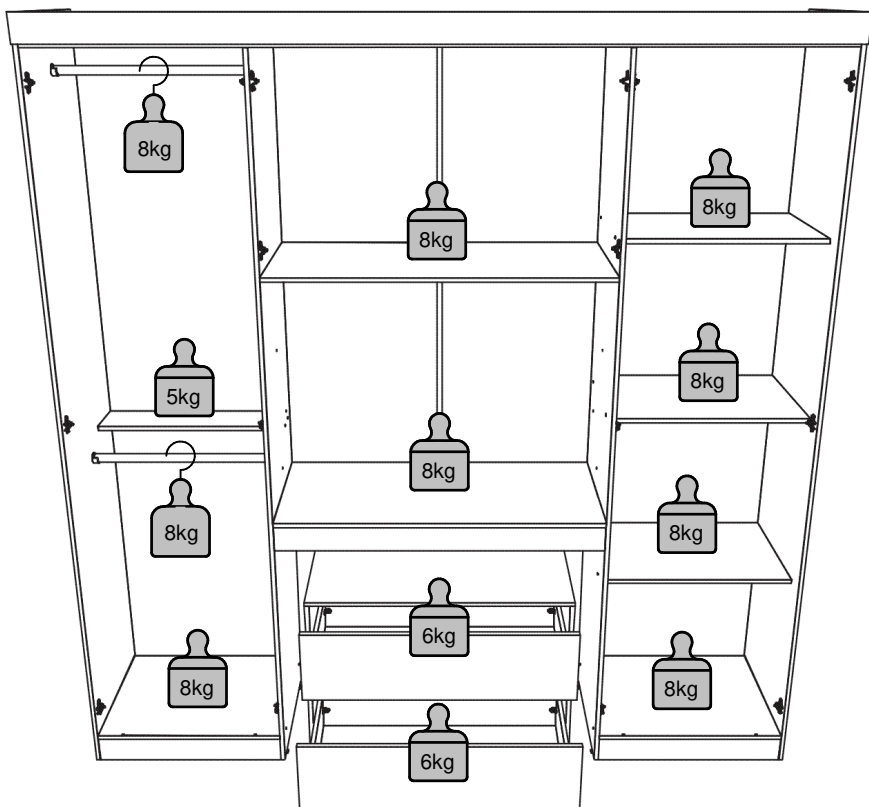

Peso por estante

Por favor, preste atención a los pesos máximos admitidos por cada compartimento del producto. Tenga cuidado de no exceder estos pesos, con el fin de garantizar la calidad y durabilidad del producto.

Es importante recordar que los pesos muestran en caso de ser distribuida en toda el área de la plataforma.

Weight per shelf

Please pay attention to the maximum weights supported by each compartment product. Be careful not to exceed these weights, in order to ensure the quality and durability of the product. It is important to remember also that the weights shown should be distributed throughout the area of the shelf.

Peso por Prateleira

Ao lado são demonstrados os pesos máximos suportados por cada compartimento do produto. Cuide para não exceder esses pesos, afim de garantir a qualidade e a durabilidade do mesmo. É importante lembrar também, que os pesos mostrados devem ser DISTRIBUÍDOS ao longo de toda a área da peça.

LISTA DE PIEZAS / LIST OF PARTS / RELAÇÃO DE PEÇAS

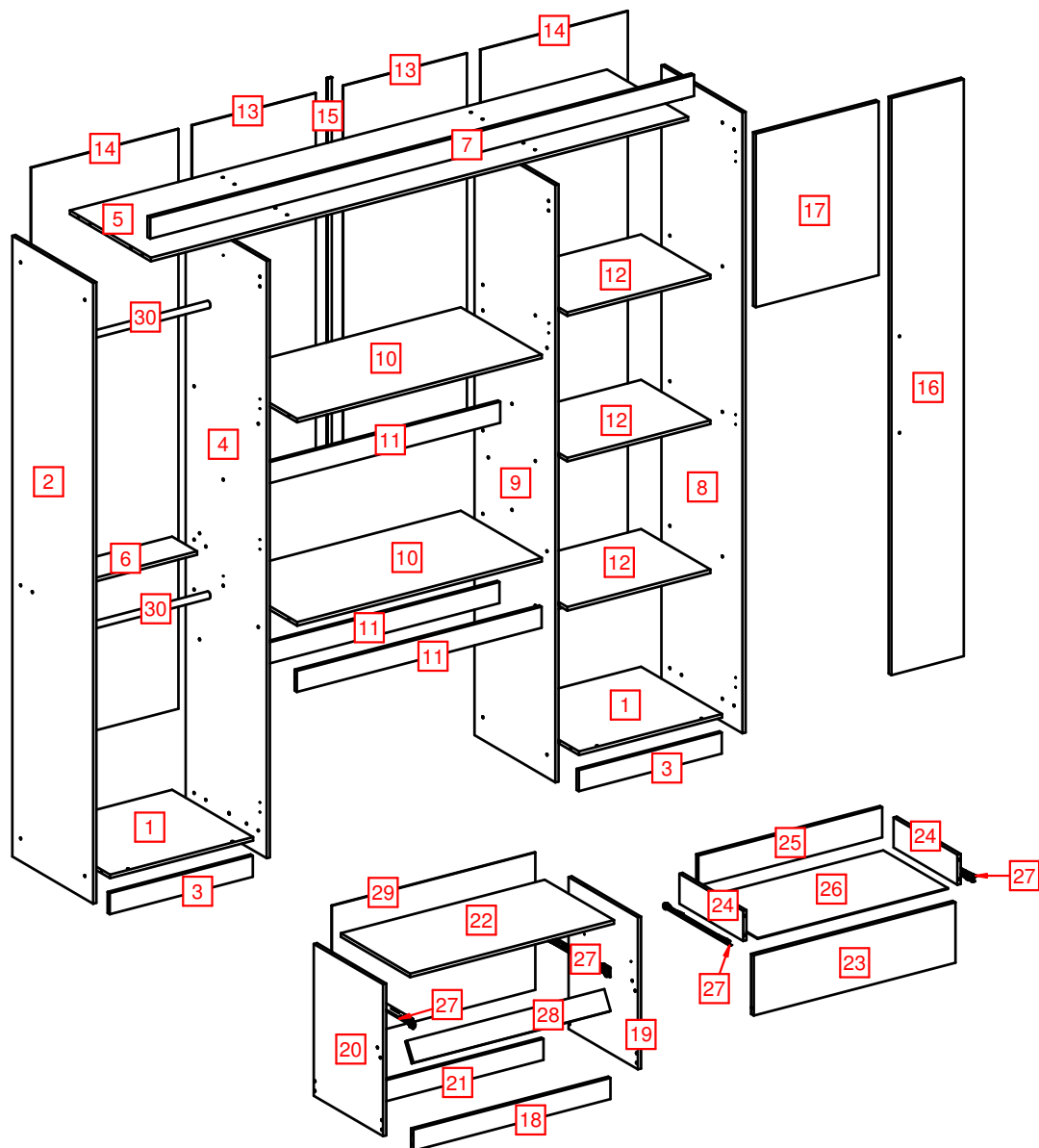

#	Qtde.	Espanhol	Inglés	Português	Dimensões	#	Qtde.	Espanhol	Inglés	Português	Dimensões
1	2	Base	Base	Base	526 x 444 x 12	16	4	Puerta Mayor	Biggest Door	Porta Maior	1915 x 266 x 15
2	1	Lateral Izquierda	Left Side	Lateral Esquerda	2060 x 444 x 12	17	2	Puerta Pequeña	Smaller Door	Porta Menor	576 x 452 x 15
3	2	Rodapié	Baseboard	Rodapé	526 x 70 x 12	18	1	Rod. Delantero Cómoda	Smaller Baseboard	Rodapé Diant. Cómoda	725 x 70 x 12
4	1	División Izquierda	Left Division	Divisão Esquerda	1982 x 444 x 12	19	1	Lat. Derecha Cómoda	Smaller Right Side	Lat. Direita Cómoda	504 x 380 x 12
5	1	Tapa	Top	Tampo	1976 x 444 x 12	20	1	Lat. Izquierda Cómoda	Smaller Left Side	Lat. Esquerda Cómoda	504 x 380 x 12
6	1	Estante Reducida	Smaller Shelf	Prateleira Reduzida	526 x 137 x 12	21	1	Rod. Trasero Cómoda	Smaller Back Baseboard	Rodapé Tras. Cómoda	725 x 70 x 12
7	1	Marco	Frame	Moldura	2000 x 70 x 15	22	1	Tapa Cómoda	Smaller Top	Tampo Cómoda	750 x 380 x 12
8	1	Lateral Derecha	Right Side	Lateral Direita	2060 x 444 x 12	23	2	Frente de Cajón	Drawer Front	Frente de Gaveta	742 x 200 x 15
9	1	División Derecha	Right Division	Divisão Direita	1982 x 444 x 12	24	4	Lateral del Cajón	Drawer Side	Lateral de Gaveta	350 x 100 x 12
10	2	Estante-Tapa Central	Shelf-Central Top	Prateleira-Tampo Central	900 x 444 x 12	25	2	Costado Cajón	Drawer Back	Costa de Gaveta	676 x 100 x 12
11	3	Soporte Tapa Central	Support Central Top	Reforço Tampo Central	900 x 70 x 12	26	2	Fondo Cajón	Drawer Bottom	Fundo de Gaveta	700 x 355 x 2,8
12	3	Estante	Shelf	Prateleira	526 x 380 x 12	27	2	Corredera Metalica	Metallic Runner	Corrediça Metálica	350mm
13	2	Costado Pequeño	Smaller Back	Costa Menor	1248 x 455 x 2,8	28	1	Soporte Delantero Cómoda	Front Support	Vista Cómoda	725 x 70 x 12
14	2	Costado Mayor	Biggest Back	Costa Maior	1924 x 542 x 2,8	29	1	Costado Cómoda	Back Chest of Drawers	Costa Cómoda	748 x 456 x 2,8
15	1	Perfil Menor	Smaller "I" Profile	Perfil I Menor	1224 x 15 x 6	30	2	Rolizo Percha	Hanger Rail	Cabideiro	Ø23 x 516

1-2x

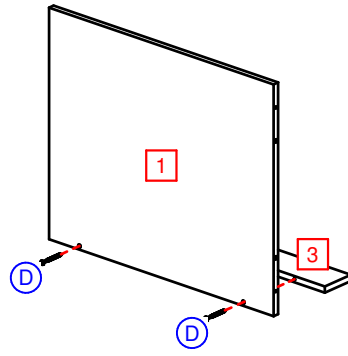

2

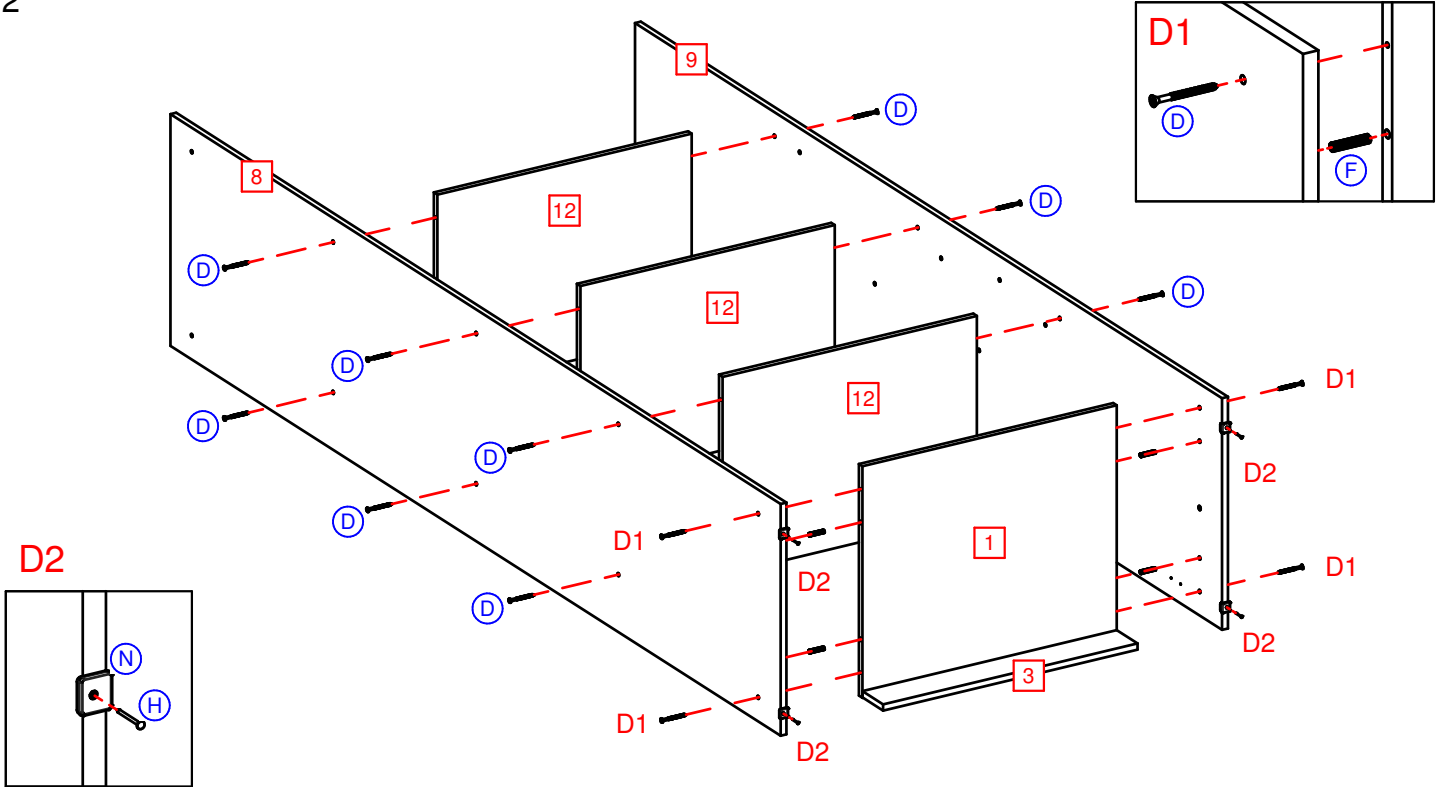

3

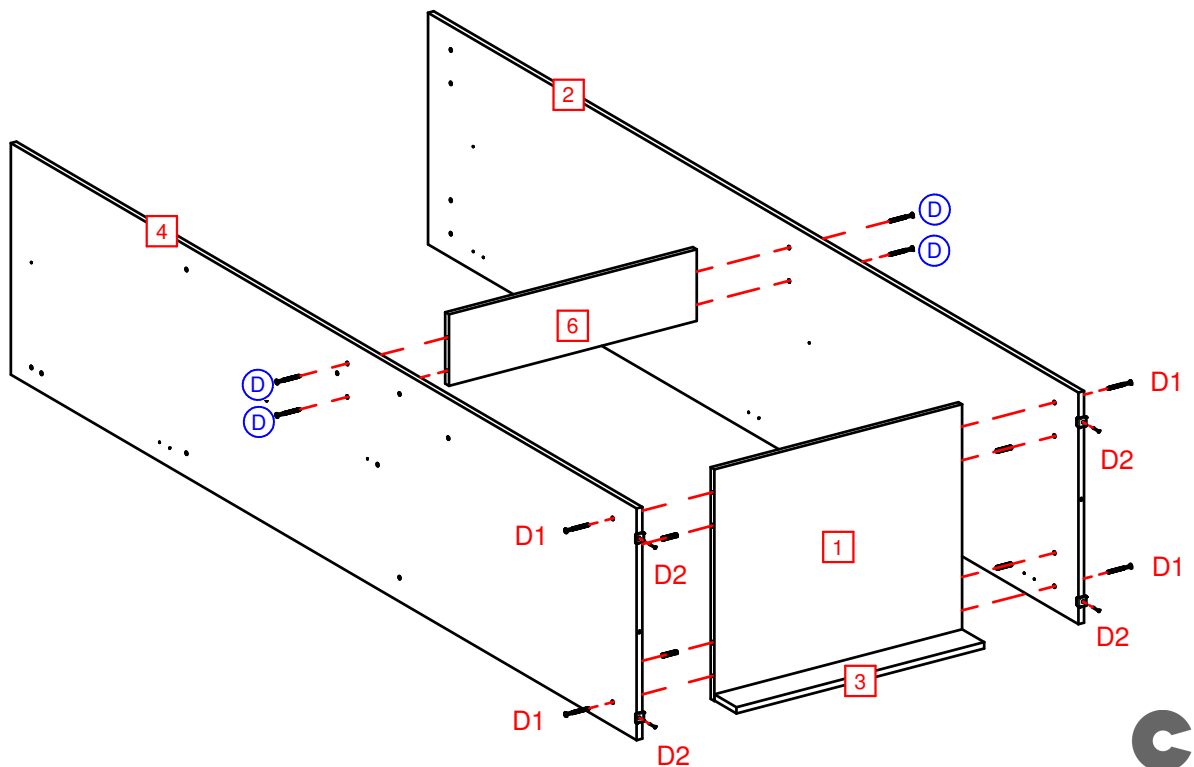

4

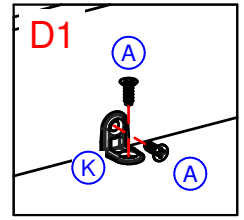
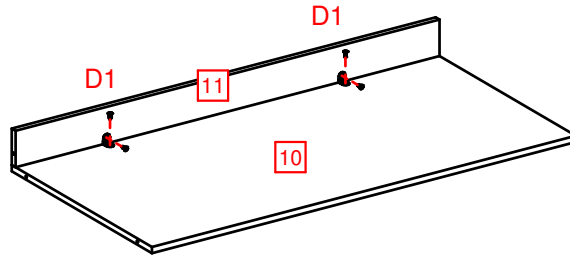
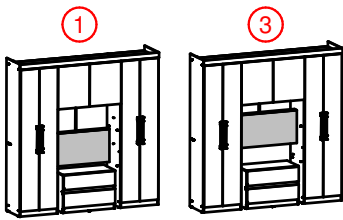

4

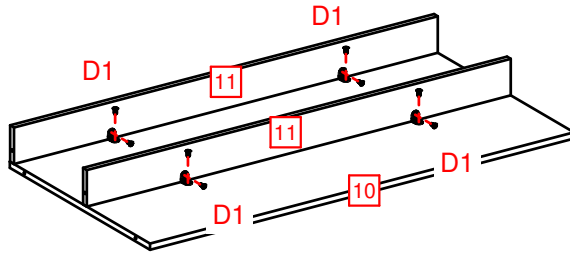
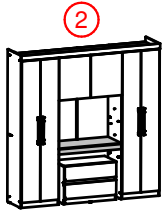

5

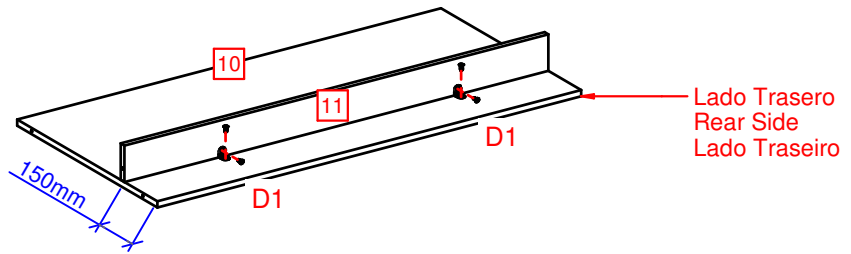
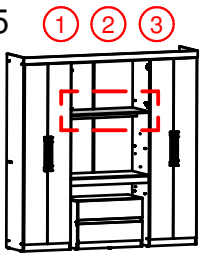

6

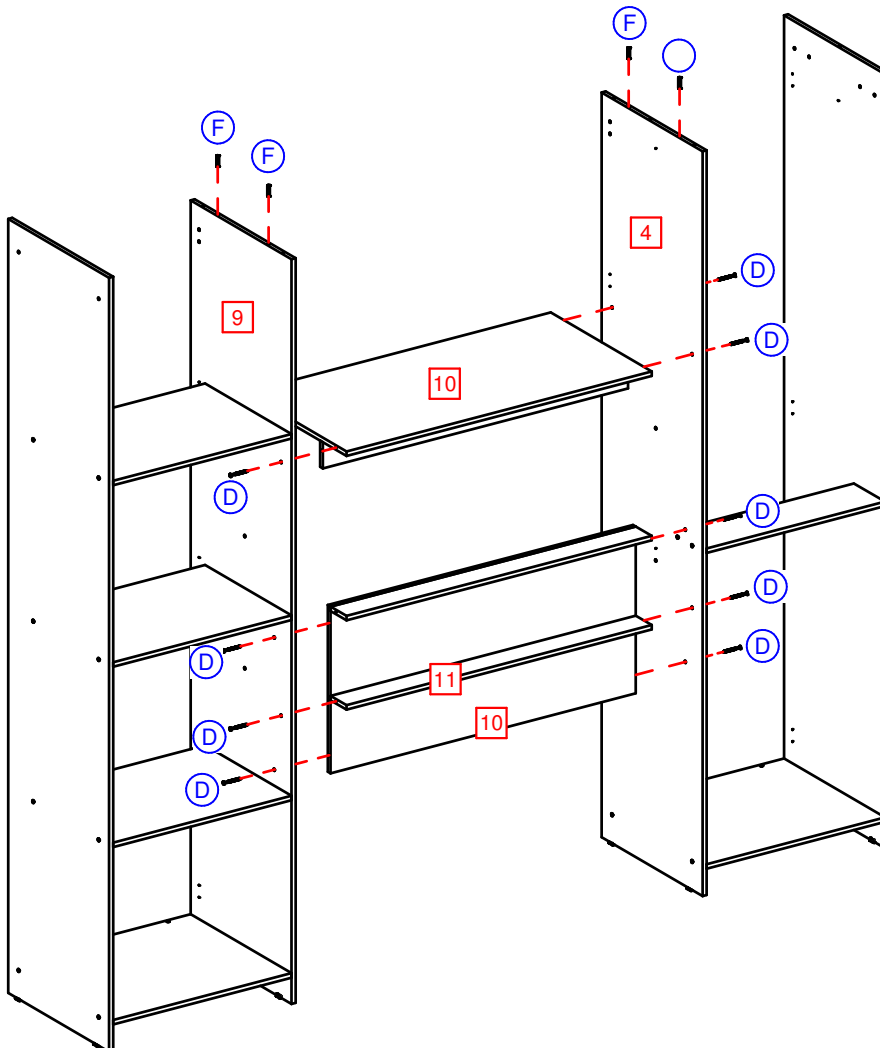
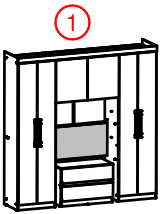

6

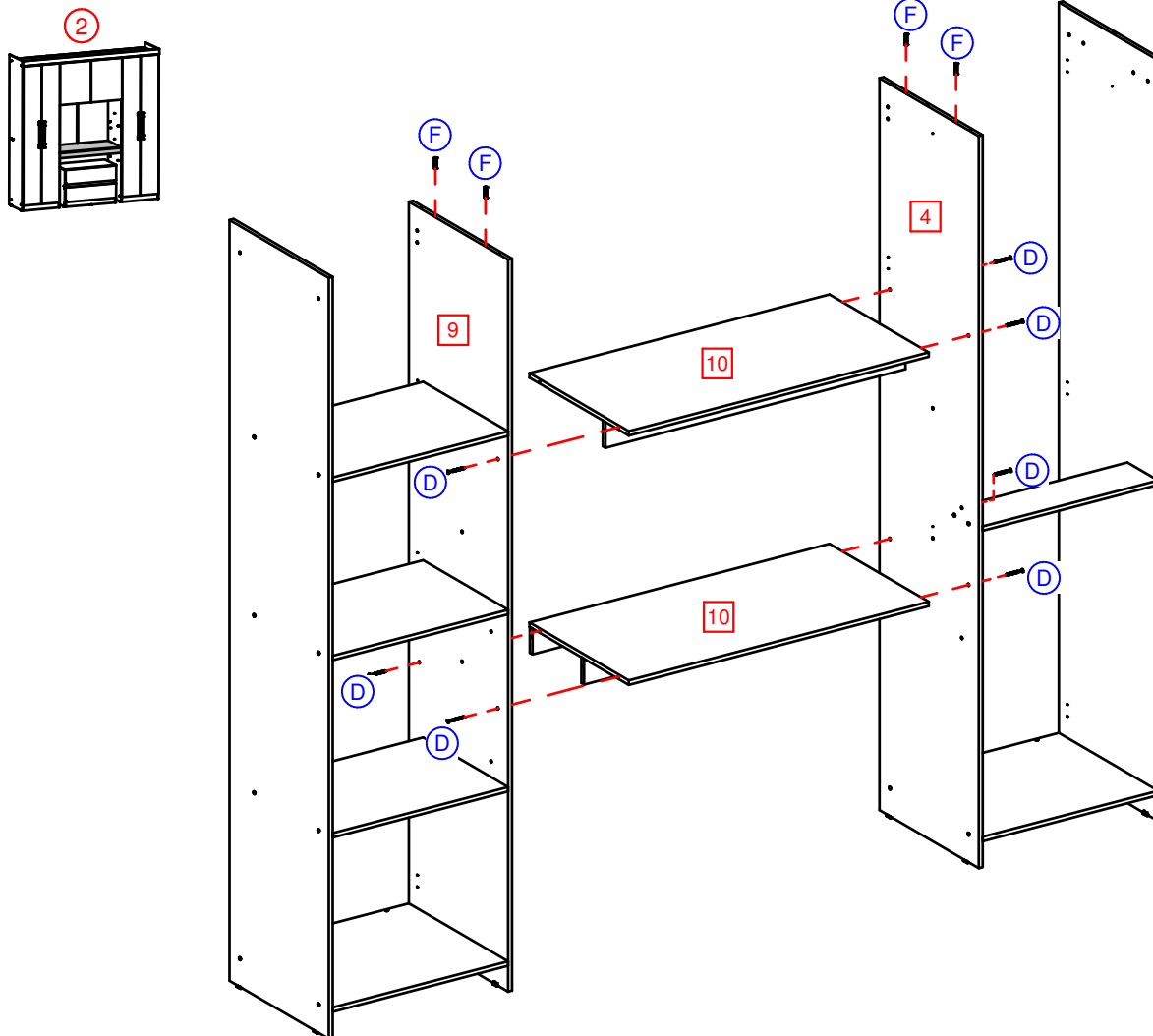

6

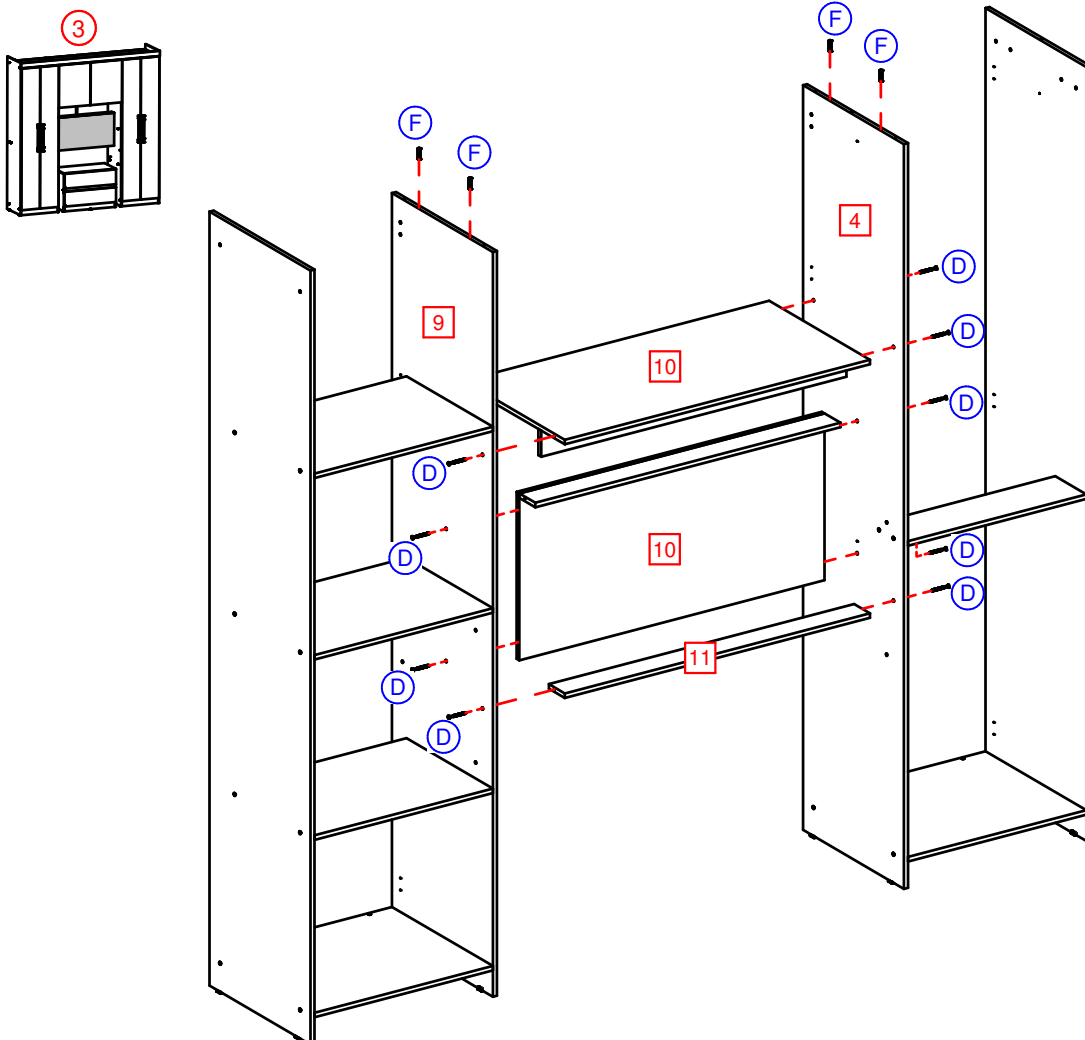

7

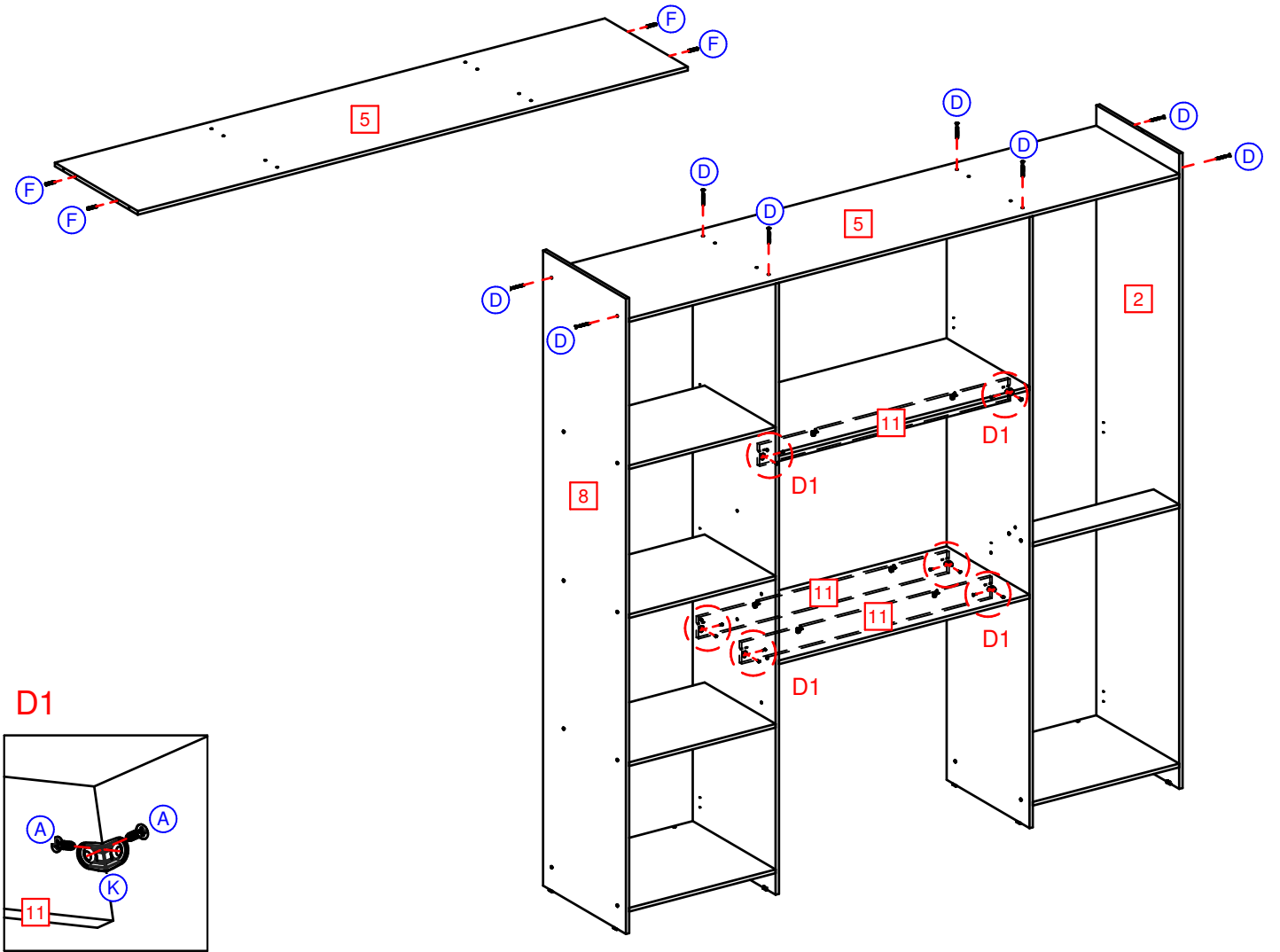

8

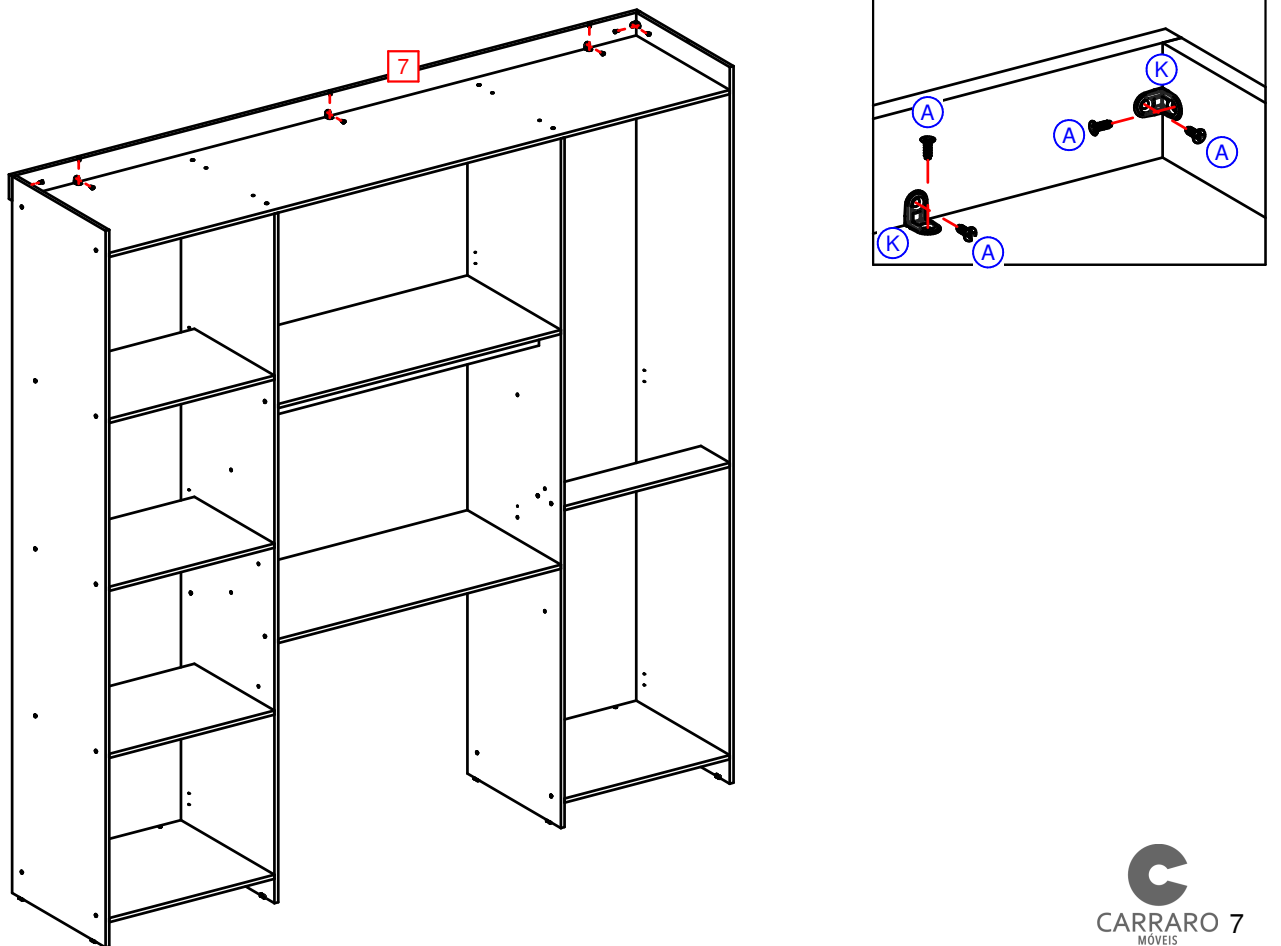

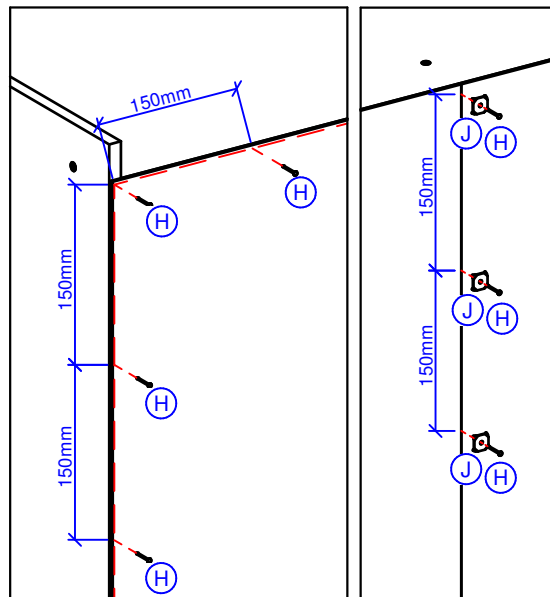
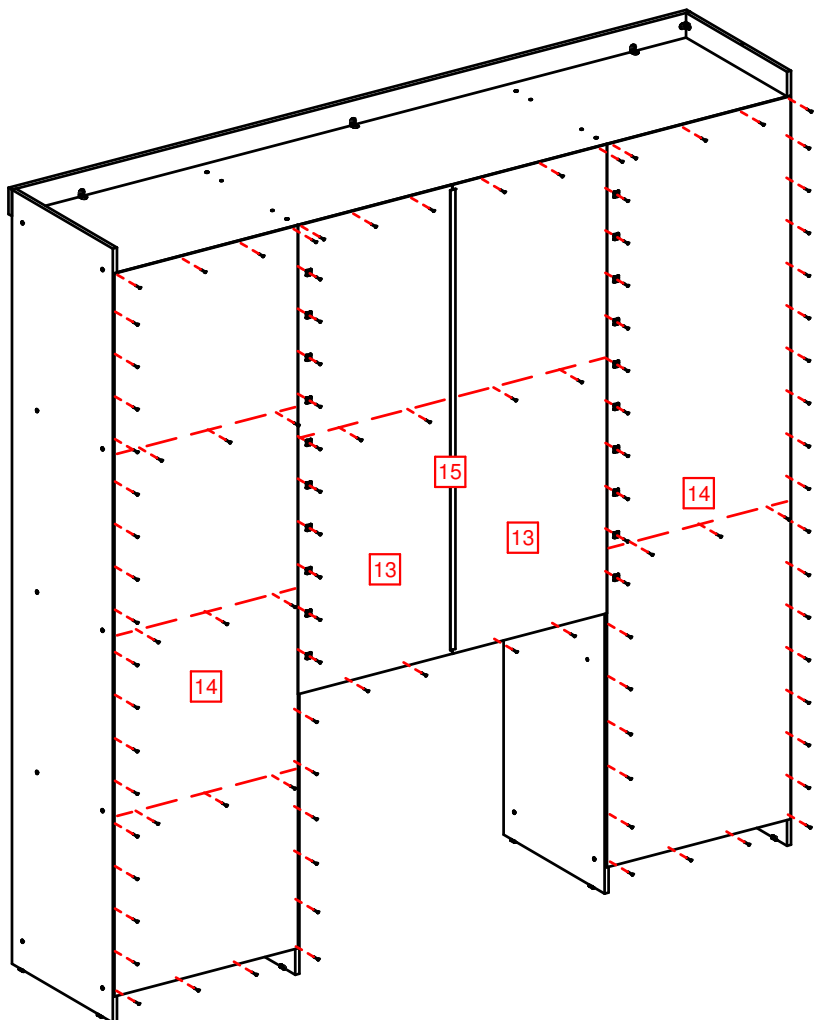

Fijar costado con clavos cada 150mm.
 Fasten back with nails every 150mm.
 Fixar costa com pregos, a cada 150mm.

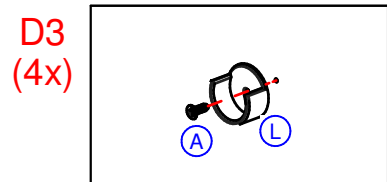
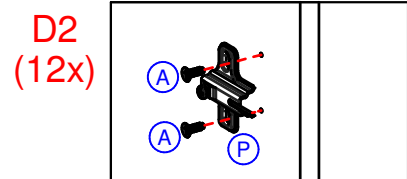
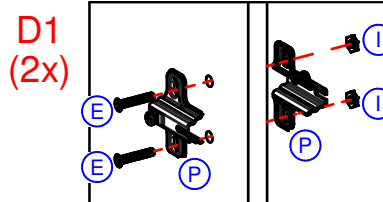
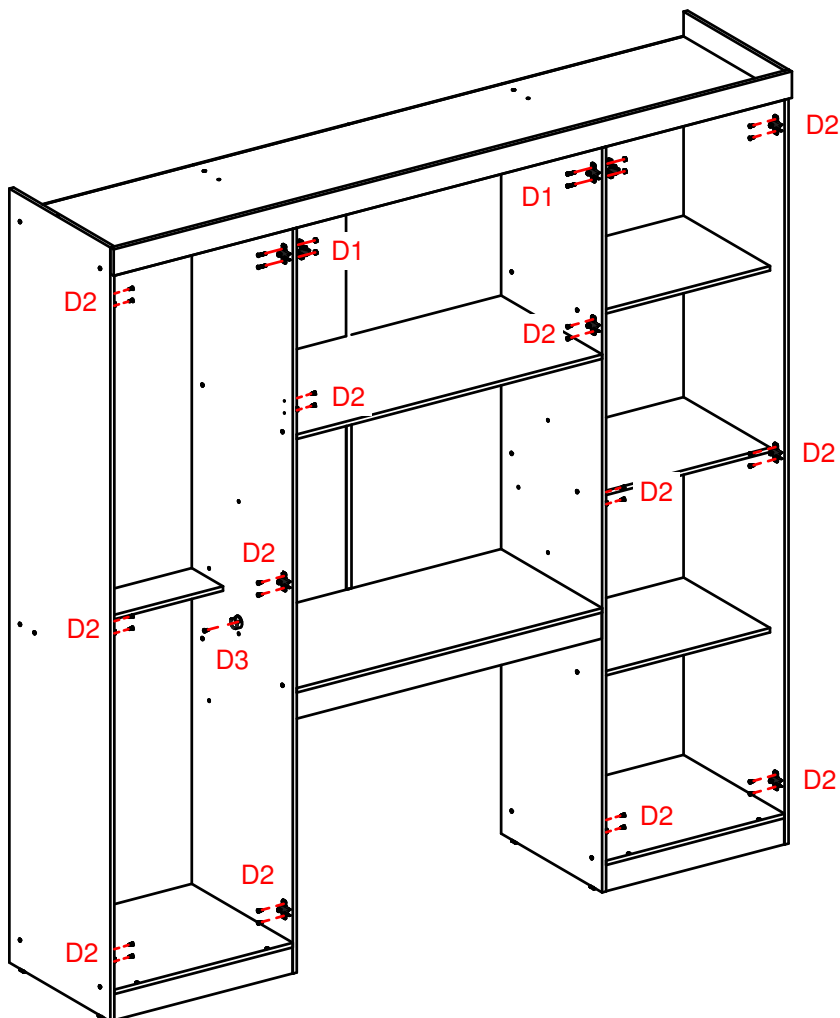

11

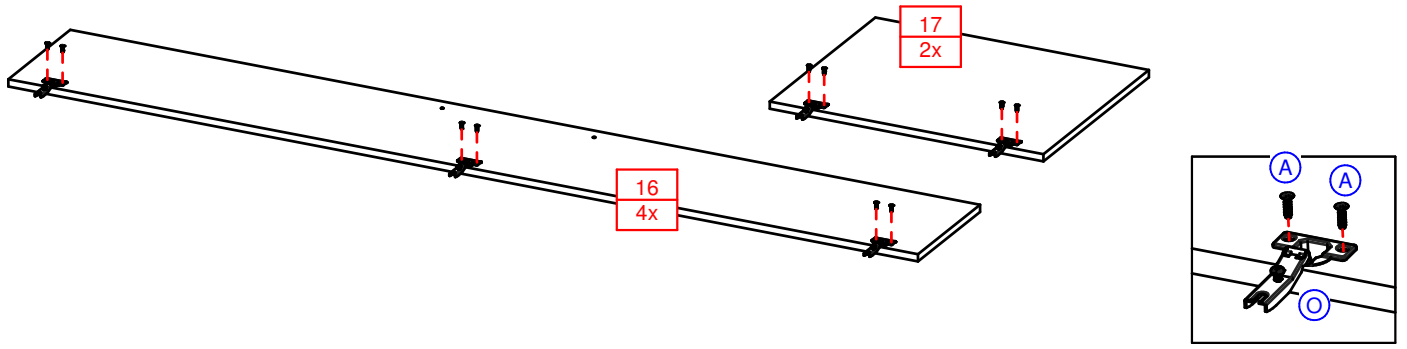

12

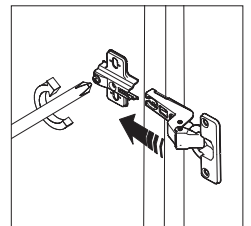
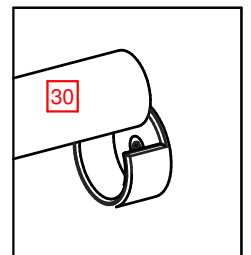
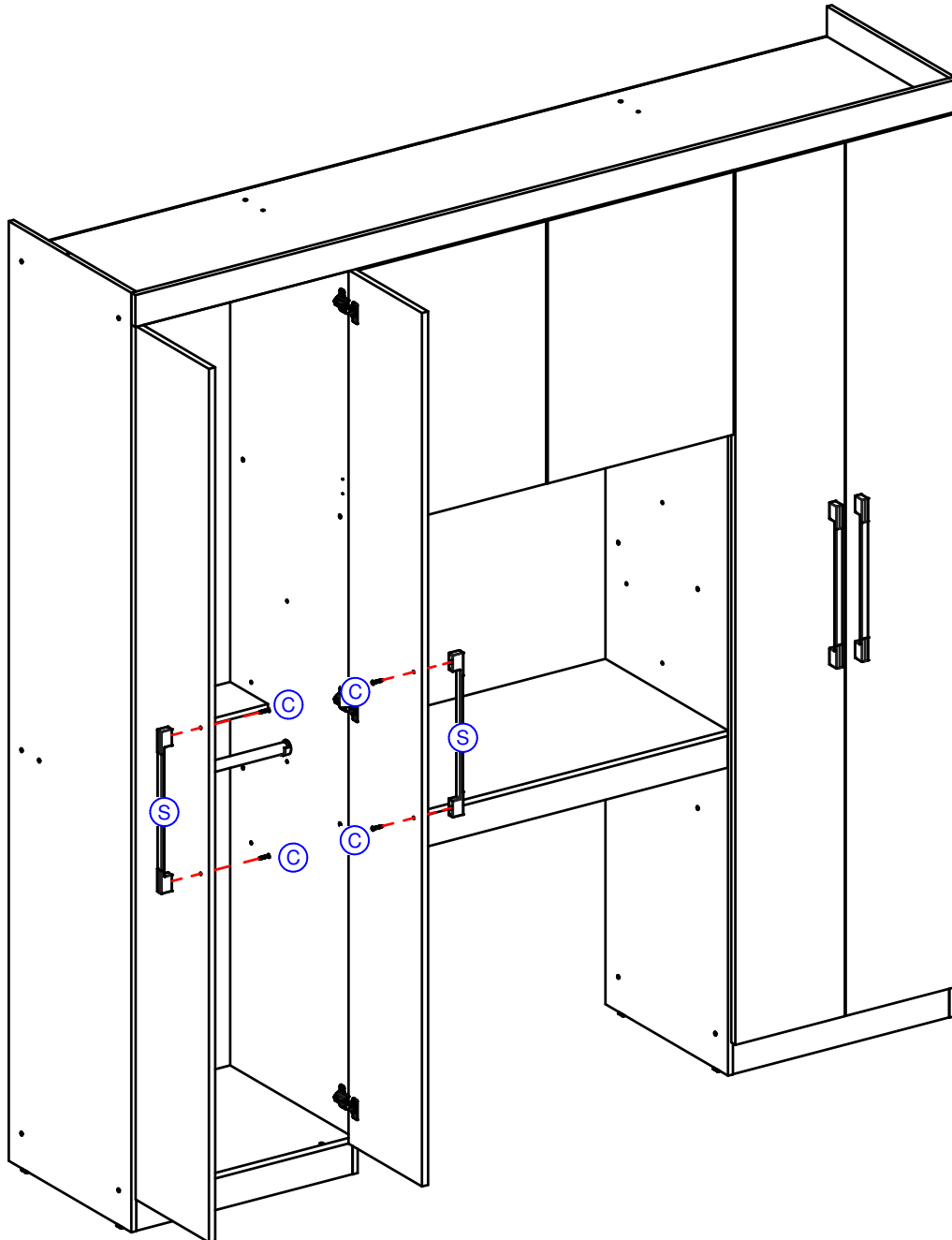

Encaje de la puerta
Door setting
Encaixe da porta

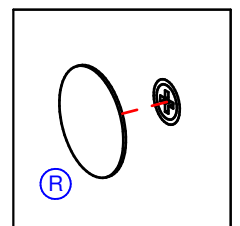

Poner tapa agujeros adhesivos, según el detalle.
Please, put adhesive hole covers, as per detail.
Colocar tapa furos adhesivos, conforme detalhe.

Ajuste das Portas / Door Adjustment / Ajuste de las Puertas

Encaixe da porta
Door setting
Encaje de la puerta

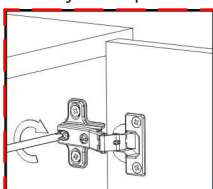

Ajuste Interno / Internal
Adjustment / Ajuste Interno

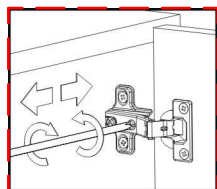

Ajuste de Altura
Height Adjustment
Ajuste del alto

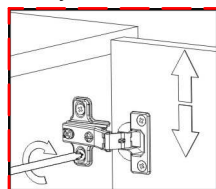

Ajuste de Profundidade
Depth Adjustment
Ajuste de la profundidad

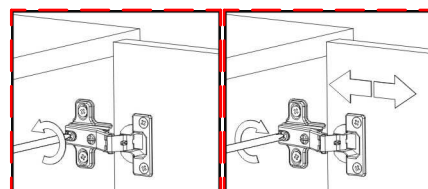

13

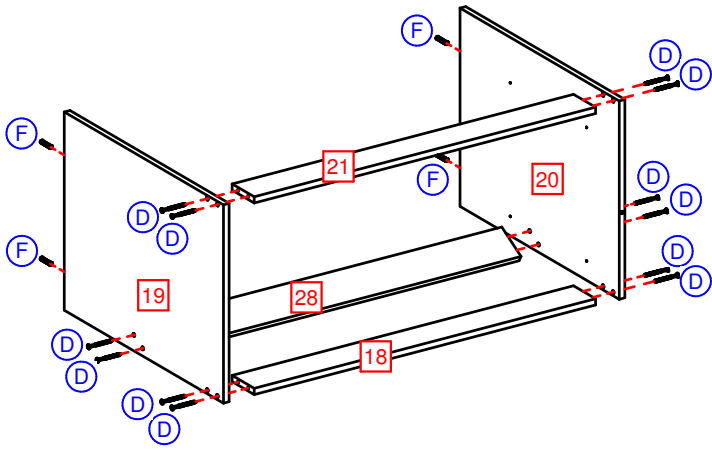

14

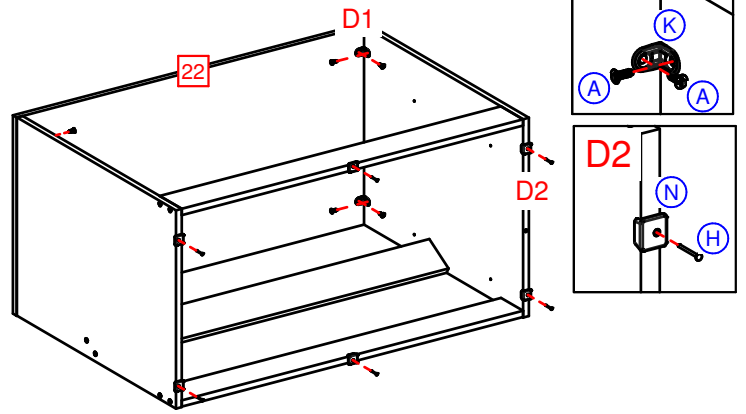

15

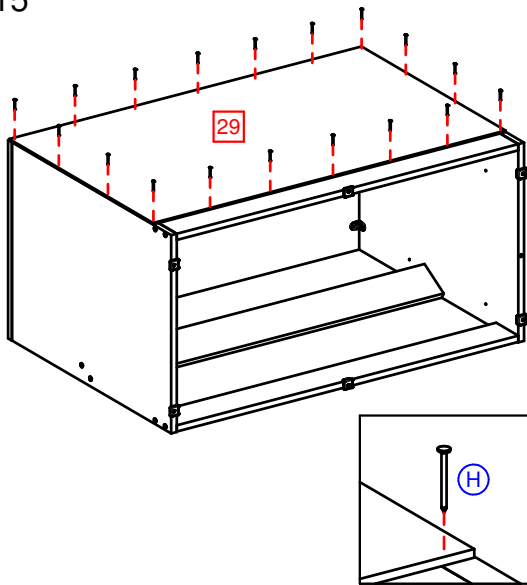

16

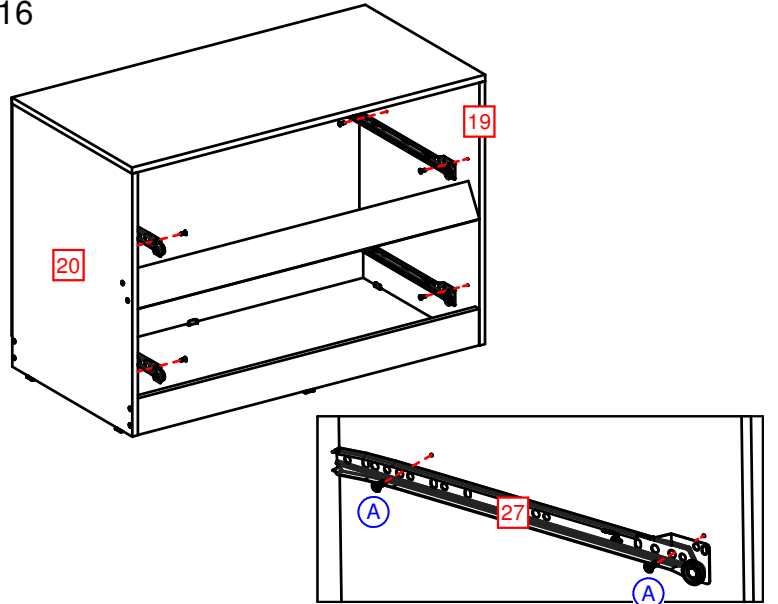

17-2x

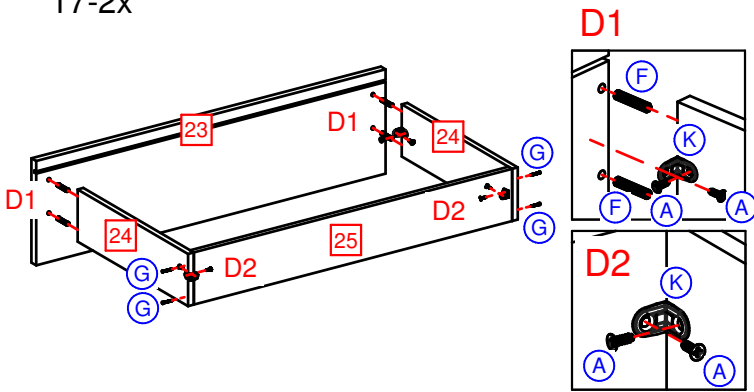

18-2x

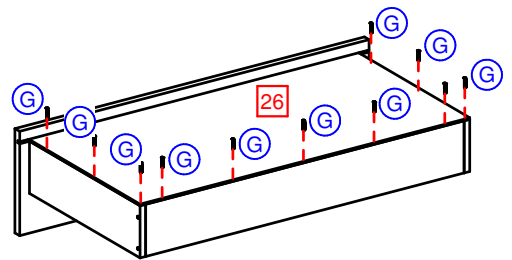

19-2x

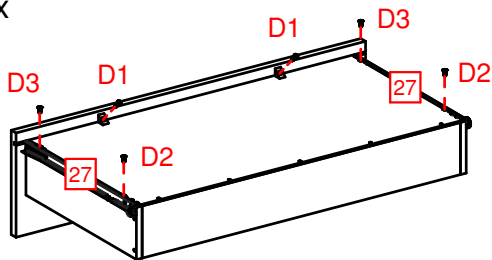

20

